

JAMB SCREW INSTALLATION

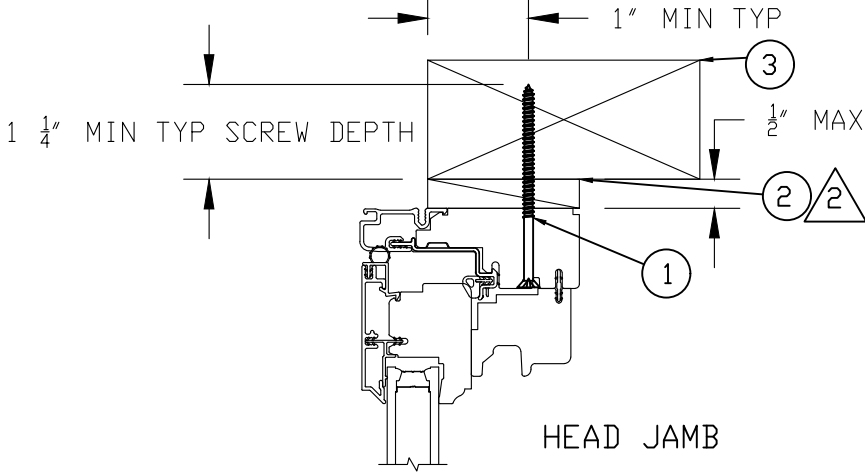

HEAD JAMB

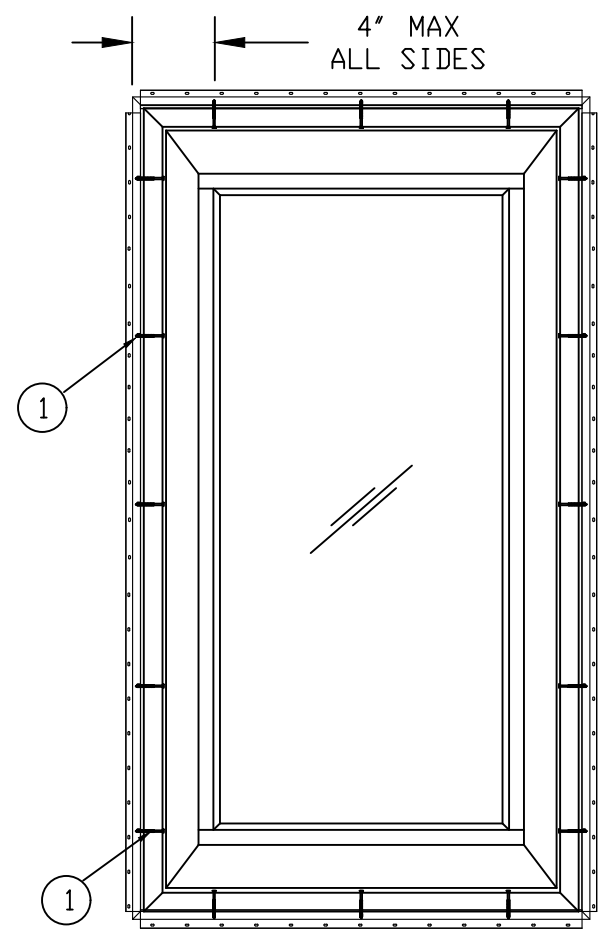

15" MAX ALL SIDES

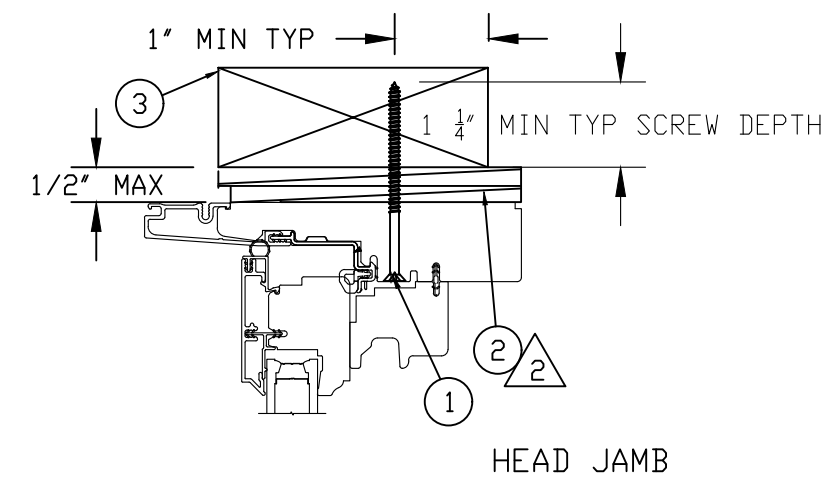

HEAD JAMB

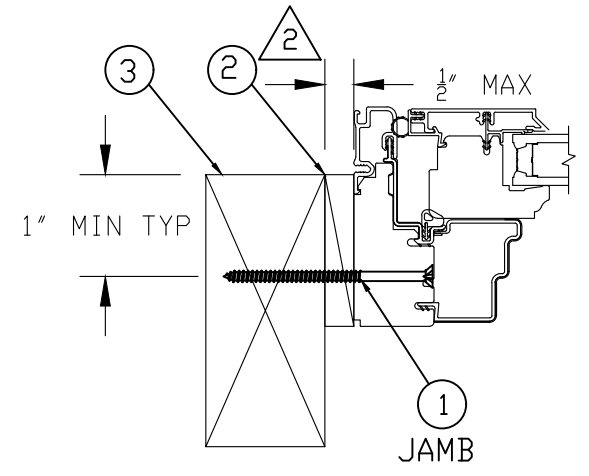

JAMB

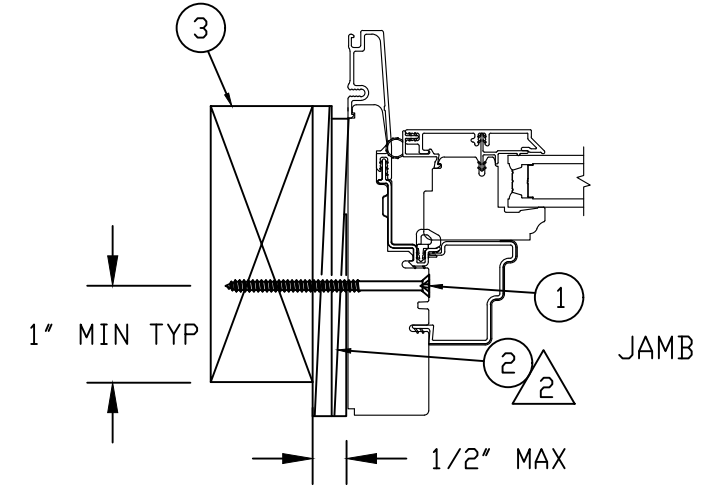

JAMB

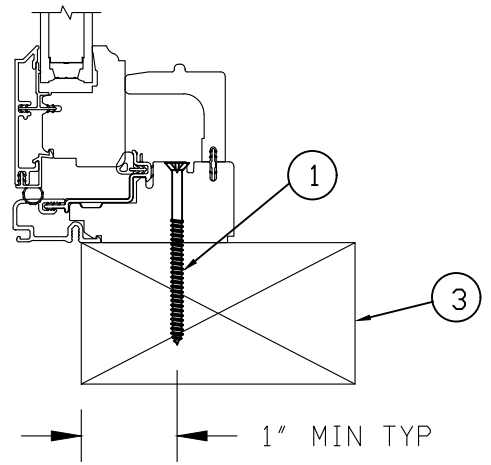

SILL

NARROW FRAME PRODUCT DETAILS

- JAMB SCREW INSTALLATION METHOD:
- UNIT MUST NOT BE IN DIRECT CONTACT WITH EITHER CONCRETE OR TREATED BUCK MATERIAL. IF SHIM SPACE IS LESS THAN 1/8" WRAPPING THE UNIT ON ALL 4 SIDES WITH WINDOW FLASHING TAPE IS REQUIRED AS A BARRIER BETWEEN THE UNIT AND CONCRETE OR TREATED LUMBER.
 - SECURE JAMBS, HEAD JAMBS AND SILL WITH #8 X 3" SCREWS.
 - SHIM AT EACH SCREW LOCATION.

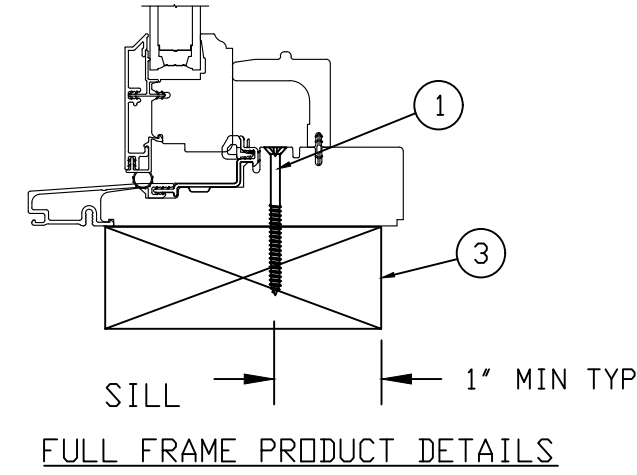
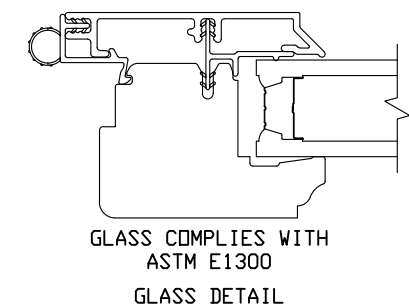

FULL FRAME PRODUCT DETAILS

- NOTES FOR ALL METHODS:
1. THIS PRINT IS FOR STRUCTURAL PERFORMANCE ONLY. FOR FLASHING & SEALING INSTRUCTIONS, REFER TO THE INSTALLATION INSTRUCTIONS.
 2. SHIMS
-PLACE A SHIM WITHIN 4-6 INCHES OF EACH CORNER AND SPACE ALL OTHERS EVENLY A MAXIMUM OF 15' APART.
 3. IF CHEMICALLY TREATED LUMBER IS USED FOR BUCK MATERIAL, FASTENERS INTO THE BUCK MUST BE A MINIMUM OF 0.90 OZ/FT² ZINC HOT DIPPED GALVANIZED OR STAINLESS STEEL TYPE 304 OR 316.

UNIT	MAX FRAME SIZE	DP RATING
UL CSMNT PD	40 X 91-1/8	+35/-35
UL CSMNT NF PD	40 X 91-1/8	+35/-35
UL CSMNT PD	36 X 96-1/8	+35/-35
UL CSMNT NF PD	36 X 96-1/8	+35/-35

ITEM NO	REF NO	DESCRIPTION
3	-----	WOOD BUCK BY OTHERS
2	-----	SHIM
1	-----	#8 X 3.000 WOOD SCREW

UNSPECIFIED TOLERANCES	
DECIMALS: XX ± .03 XXX ± .012	ANGLE DEG: ± .5
LINEAL: + .125 - .000	FAB LINEAL: ± N/A
MATERIAL: N/A	

MARVIN  **RESEARCH & DEVELOPMENT**

PRODUCT ULTIMATE CASEMENT
CATEGORY:
UNIT TYPE: UCAPO, UCANFPO

DWG TYPE: INSTALLATION
DESCRIPTION: INSTALLATION

CHK:	SIZE: B	CLASS:	DWG NO: 00065809
APP:	SCALE: NA	DATE: 10/21/09	DWG BY: BORNEMAN, SKIP
			SHEET: 1 OF 1

NOTICE - CONFIDENTIAL INFORMATION

The information in this document is privileged and strictly confidential. The information contained herein shall be used only by Marvin Windows and Doors employees and by those agents or suppliers granted official written permission. If the reader of this document is not the intended recipient, or the employee or agent of the intended recipient, please delete this document from all data storage devices, and destroy all hard copies. Any unauthorized dissemination, distribution, copying or other use of the information contained in this document is strictly prohibited.